

MC100LVEP111

2.5V / 3.3V 1:10 Differential ECL/PECL/HSTL Clock Driver

Description

The MC100LVEP111 is a low skew 1-to-10 differential driver, designed with clock distribution in mind, accepting two clock sources into an input multiplexer. The PECL input signals can be either differential or single-ended (if the V_{BB} output is used). HSTL inputs can be used when the LVEP111 is operating under PECL conditions.

The LVEP111 specifically guarantees low output-to-output skew. Optimal design, layout, and processing minimize skew within a device and from device to device.

To ensure tightest skew, both sides of differential outputs identically terminate into $50\ \Omega$ even if only one output is being used. If an output pair is unused, both outputs may be left open (unterminated) without affecting skew.

The MC100LVEP111, as with most other ECL devices, can be operated from a positive V_{CC} supply in PECL mode. This allows the LVEP111 to be used for high performance clock distribution in +3.3 V or +2.5 V systems. Single-ended CLK input operation is limited to a $V_{CC} \geq 3.0$ V in PECL mode, or $V_{EE} \leq -3.0$ V in NECL mode when using V_{BB} (See Figure 10). Full operating range is available when using an external voltage reference (See Figure 9). Designers can take advantage of the LVEP111's performance to distribute low skew clocks across the backplane or the board.

Features

- 85 ps Typical Device-to-Device Skew
- 20 ps Typical Output-to-Output Skew
- Jitter Less than 1 ps RMS
- Maximum Frequency > 3 GHz Typical
- V_{BB} Output
- 430 ps Typical Propagation Delay
- The 100 Series Contains Temperature Compensation
- PECL and HSTL Mode Operating Range: $V_{CC} = 2.375$ V to 3.8 V with $V_{EE} = 0$ V
- NECL Mode Operating Range: $V_{CC} = 0$ V with $V_{EE} = -2.375$ V to -3.8 V
- Open Input Default State
- LVDS Input Compatible
- Fully Compatible with MC100EP111
- Pb-Free Packages are Available



ON Semiconductor®

<http://onsemi.com>

MARKING DIAGRAMS*



LQFP-32
FA SUFFIX
CASE 873A

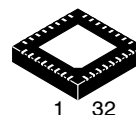
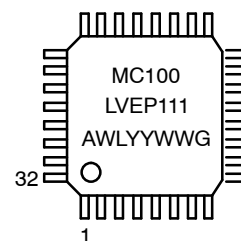

QFN32
MN SUFFIX
CASE 488AM

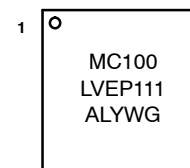

A = Assembly Location
WL, L = Wafer Lot
YY, Y = Year
WW, W = Work Week
G = Pb-Free Package

*For additional marking information, refer to Application Note AND8002/D.

ORDERING INFORMATION

See detailed ordering and shipping information in the package dimensions section on page 10 of this data sheet.

MC100LVEP111

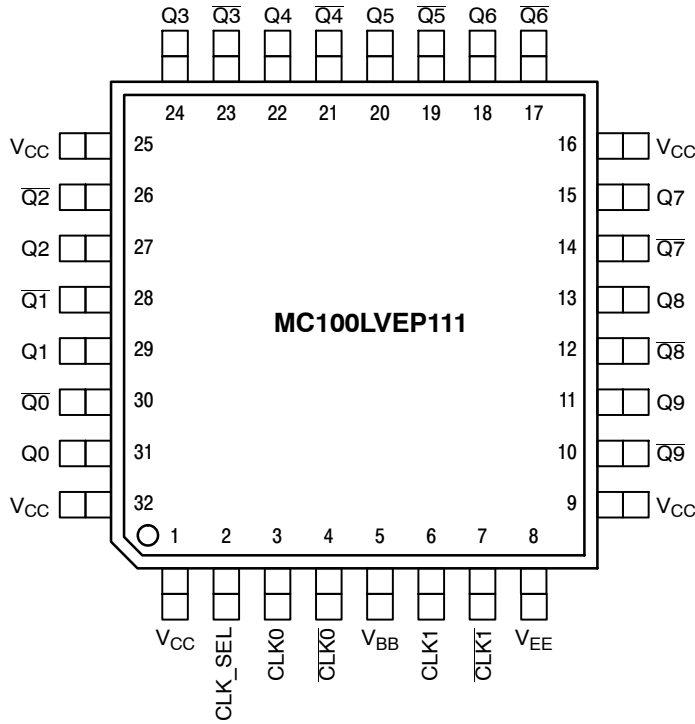

Warning: All V_{CC} and V_{EE} pins must be externally connected to Power Supply to guarantee proper operation.

Figure 1. LQFP-32 Pinout (Top View)

Table 1. PIN DESCRIPTION

PIN	FUNCTION
CLK0*, $\overline{\text{CLK0}}^{**}$	ECL/PECL/HSTL CLK Input
CLK1*, $\overline{\text{CLK1}}^{**}$	ECL/PECL/HSTL CLK Input
Q0:9, $\overline{\text{Q0}}:9$	ECL/PECL Outputs
CLK_SEL*	ECL/PECL Active Clock Select Input
V _{BB}	Reference Voltage Output
V _{CC}	Positive Supply
V _{EE}	Negative Supply
EP	The exposed pad (EP) on the package bottom must be attached to a heat-sinking conduit. The exposed pad may only be electrically connected to V _{EE} .

* Pins will default LOW when left open.

** Pins will default to 2/3V_{CC} when left open.

Table 2. FUNCTION TABLE

CLK_SEL	Active Input
L	CLK0, $\overline{\text{CLK0}}$
H	CLK1, $\overline{\text{CLK1}}$

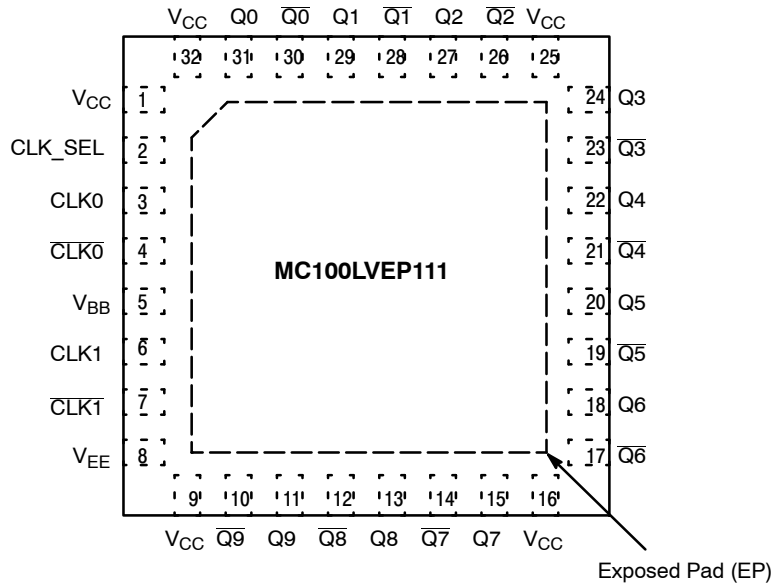

Figure 2. QFN-32 Pinout (Top View)

MC100LVEP111

Table 3. ATTRIBUTES

Characteristics		Value	
Internal Input Pulldown Resistor		75 k Ω	
Internal Input Pullup Resistor		37.5 k Ω	
ESD Protection	Human Body Model Machine Model Charged Device Model	> 2 kV > 100 V > 2 kV	
Moisture Sensitivity (Note 1)		Pb Pkgs	Pb-Free Pkgs
		LQFP Level 2	Level 2
		QFN Level 1	Level 1
Flammability Rating	Oxygen Index: 28 to 34	UL 94 V-0 @ 0.125 in	
Transistor Count		602 Devices	
Meets or exceeds JEDEC Spec EIA/JESD78 IC Latchup Test			

1. For additional information, refer to Application Note AND8003/D.

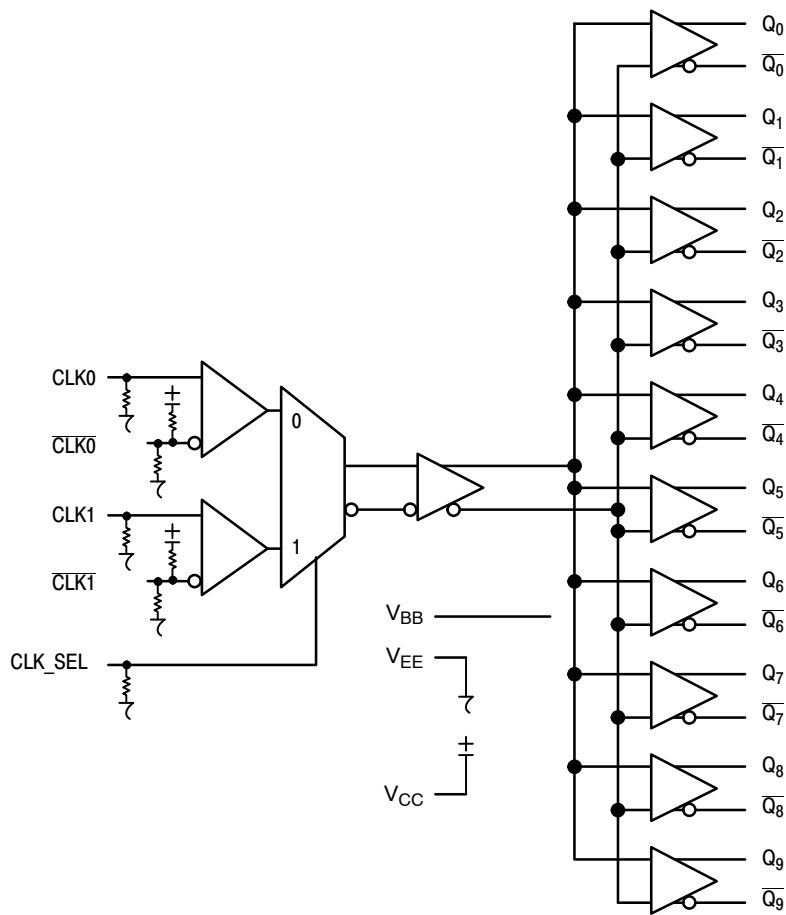

Figure 3. Logic Diagram

MC100LVEP111

Table 4. MAXIMUM RATINGS

Symbol	Parameter	Condition 1	Condition 2	Rating	Unit
V_{CC}	PECL Mode Power Supply	$V_{EE} = 0\text{ V}$		6	V
V_{EE}	NECL Mode Power Supply	$V_{CC} = 0\text{ V}$		-6	V
V_I	PECL Mode Input Voltage NECL Mode Input Voltage	$V_{EE} = 0\text{ V}$ $V_{CC} = 0\text{ V}$	$V_I \leq V_{CC}$ $V_I \geq V_{EE}$	6 -6	V V
I_{out}	Output Current	Continuous Surge		50 100	mA mA
I_{BB}	V_{BB} Sink/Source			± 0.5	mA
T_A	Operating Temperature Range			-40 to +85	$^{\circ}\text{C}$
T_{stg}	Storage Temperature Range			-65 to +150	$^{\circ}\text{C}$
θ_{JA}	Thermal Resistance (Junction-to-Ambient)	0 lfpm 500 lfpm	LQFP-32 LQFP-32	80 55	$^{\circ}\text{C}/\text{W}$ $^{\circ}\text{C}/\text{W}$
θ_{JC}	Thermal Resistance (Junction-to-Case)	Standard Board	LQFP-32	12 to 17	$^{\circ}\text{C}/\text{W}$
θ_{JA}	Thermal Resistance (Junction-to-Ambient)	0 lfpm 500 lfpm	QFN-32 QFN-32	31 27	$^{\circ}\text{C}/\text{W}$ $^{\circ}\text{C}/\text{W}$
θ_{JC}	Thermal Resistance (Junction-to-Case)	2S2P	QFN-32	12	$^{\circ}\text{C}/\text{W}$
T_{sol}	Wave Solder Pb Pb-Free (QFN-32 Only)	< 3 sec @ 248 $^{\circ}\text{C}$ < 3 sec @ 260 $^{\circ}\text{C}$		265 265	$^{\circ}\text{C}$

Stresses exceeding Maximum Ratings may damage the device. Maximum Ratings are stress ratings only. Functional operation above the Recommended Operating Conditions is not implied. Extended exposure to stresses above the Recommended Operating Conditions may affect device reliability.

MC100LVEP111

Table 5. PECL DC CHARACTERISTICS $V_{CC} = 2.5\text{ V}$; $V_{EE} = 0\text{ V}$ (Note 2)

Symbol	Characteristic	-40°C			25°C			85°C			Unit
		Min	Typ	Max	Min	Typ	Max	Min	Typ	Max	
I_{EE}	Power Supply Current	60	90	120	60	90	120	60	90	120	mA
V_{OH}	Output HIGH Voltage (Note 3)	1355	1480	1605	1355	1480	1605	1355	1480	1605	mV
V_{OL}	Output LOW Voltage (Note 3)	555	730	900	555	730	900	555	730	900	mV
V_{IH}	Input HIGH Voltage (Single-Ended) (Note 4)	1335		1620	1335		1620	1275		1620	mV
V_{IL}	Input LOW Voltage (Single-Ended) (Note 4)	555		875	555		875	555		875	mV
V_{IHCMR}	Input HIGH Voltage Common Mode Range (Differential Configuration) (Note 5)	1.2		2.5	1.2		2.5	1.2		2.5	V
I_{IH}	Input HIGH Current			150			150			150	μA
I_{IL}	Input LOW Current	CLK CLK	0.5 -150		0.5 -150			0.5 -150			μA

NOTE: Device will meet the specifications after thermal equilibrium has been established when mounted in a test socket or printed circuit board with maintained transverse airflow greater than 500 lfm. Electrical parameters are guaranteed only over the declared operating temperature range. Functional operation of the device exceeding these conditions is not implied. Device specification limit values are applied individually under normal operating conditions and not valid simultaneously.

- Input and output parameters vary 1:1 with V_{CC} . V_{EE} can vary + 0.125 V to -1.3 V.
- All loading with 50 Ω to V_{EE} .
- Do not use V_{BB} at $V_{CC} < 3.0\text{ V}$.
- V_{IHCMR} min varies 1:1 with V_{EE} , V_{IHCMR} max varies 1:1 with V_{CC} . The V_{IHCMR} range is referenced to the most positive side of the differential input signal.

Table 6. PECL DC CHARACTERISTICS $V_{CC} = 3.3\text{ V}$; $V_{EE} = 0\text{ V}$ (Note 6)

Symbol	Characteristic	-40°C			25°C			85°C			Unit
		Min	Typ	Max	Min	Typ	Max	Min	Typ	Max	
I_{EE}	Power Supply Current	60	90	120	60	90	120	60	90	120	mA
V_{OH}	Output HIGH Voltage (Note 7)	2155	2280	2405	2155	2280	2405	2155	2280	2405	mV
V_{OL}	Output LOW Voltage (Note 7)	1355	1530	1700	1355	1530	1700	1355	1530	1700	mV
V_{IH}	Input HIGH Voltage (Single-Ended)	2135		2420	2135		2420	2135		2420	mV
V_{IL}	Input LOW Voltage (Single-Ended)	1355		1675	1355		1675	1355		1675	mV
V_{BB}	Output Reference Voltage (Note 8)	1775	1875	1975	1775	1875	1975	1775	1875	1975	mV
V_{IHCMR}	Input HIGH Voltage Common Mode Range (Differential Configuration) (Note 9)	1.2		3.3	1.2		3.3	1.2		3.3	V
I_{IH}	Input HIGH Current			150			150			150	μA
I_{IL}	Input LOW Current	CLK CLK	0.5 -150		0.5 -150			0.5 -150			μA

NOTE: Device will meet the specifications after thermal equilibrium has been established when mounted in a test socket or printed circuit board with maintained transverse airflow greater than 500 lfm. Electrical parameters are guaranteed only over the declared operating temperature range. Functional operation of the device exceeding these conditions is not implied. Device specification limit values are applied individually under normal operating conditions and not valid simultaneously.

- Input and output parameters vary 1:1 with V_{CC} . V_{EE} can vary + 0.925 V to -0.5 V.
- All loading with 50 Ω to $V_{CC} - 2.0\text{ V}$.
- Single ended input operation is limited $V_{CC} \geq 3.0\text{ V}$ in PECL mode.
- V_{IHCMR} min varies 1:1 with V_{EE} , V_{IHCMR} max varies 1:1 with V_{CC} . The V_{IHCMR} range is referenced to the most positive side of the differential input signal.

MC100LVEP111

Table 7. NECL DC CHARACTERISTICS $V_{CC} = 0\text{ V}$, $V_{EE} = -2.375\text{ V}$ to -3.8 V (Note 10)

Symbol	Characteristic	-40°C			25°C			85°C			Unit
		Min	Typ	Max	Min	Typ	Max	Min	Typ	Max	
I_{EE}	Power Supply Current	60	90	120	60	90	120	60	90	120	mA
V_{OH}	Output HIGH Voltage (Note 11)	-1145	-1020	-895	-1145	-1020	-895	-1145	-1020	-895	mV
V_{OL}	Output LOW Voltage (Note 11)	-1945	-1770	-1600	-1945	-1770	-1600	-1945	-1770	-1600	mV
V_{IH}	Input HIGH Voltage (Single-Ended)	-1165		-880	-1165		-880	-1165		-880	mV
V_{IL}	Input LOW Voltage (Single-Ended)	-1945		-1625	-1945		-1625	-1945		-1625	mV
V_{BB}	Output Reference Voltage (Note 12)	-1525	-1425	-1325	-1525	-1425	-1325	-1525	-1425	-1325	mV
V_{IHCMR}	Input HIGH Voltage Common Mode Range (Differential Configuration) (Note 13)	$V_{EE} + 1.2$		0.0	$V_{EE} + 1.2$		0.0	$V_{EE} + 1.2$		0.0	V
I_{IH}	Input HIGH Current			150			150			150	μA
I_{IL}	Input LOW Current	$\frac{\text{CLK}}{\text{CLK}}$ 0.5 -150			0.5 -150			0.5 -150			μA

NOTE: Device will meet the specifications after thermal equilibrium has been established when mounted in a test socket or printed circuit board with maintained transverse airflow greater than 500 lpm. Electrical parameters are guaranteed only over the declared operating temperature range. Functional operation of the device exceeding these conditions is not implied. Device specification limit values are applied individually under normal operating conditions and not valid simultaneously.

10. Input and output parameters vary 1:1 with V_{CC} .

11. All loading with $50\ \Omega$ to $V_{CC} - 2.0\text{ V}$.

12. Single ended input operation is limited $V_{EE} \leq -3.0\text{ V}$ in NECL mode.

13. V_{IHCMR} min varies 1:1 with V_{EE} , V_{IHCMR} max varies 1:1 with V_{CC} . The V_{IHCMR} range is referenced to the most positive side of the differential input signal.

Table 8. HSTL DC CHARACTERISTICS $V_{CC} = 2.375$ to 3.8 V , $V_{EE} = 0\text{ V}$

Symbol	Characteristic	-40°C			25°C			85°C			Unit
		Min	Typ	Max	Min	Typ	Max	Min	Typ	Max	
V_{IH}	Input HIGH Voltage	1200			1200			1200			mV
V_{IL}	Input LOW Voltage			400			400			400	mV
V_x	Input Crossover Voltage	680		900	680		900	680		900	mV
I_{CC}	Power Supply Current	70	100	120	70	100	120	70	100	120	mA

NOTE: Device will meet the specifications after thermal equilibrium has been established when mounted in a test socket or printed circuit board with maintained transverse airflow greater than 500 lpm. Electrical parameters are guaranteed only over the declared operating temperature range. Functional operation of the device exceeding these conditions is not implied. Device specification limit values are applied individually under normal operating conditions and not valid simultaneously.

MC100LVEP111

Table 9. AC CHARACTERISTICS $V_{CC} = 0\text{ V}$; $V_{EE} = -2.375\text{ to }-3.8\text{ V}$ or $V_{CC} = 2.375\text{ to }3.8\text{ V}$; $V_{EE} = 0\text{ V}$ (Note 14)

Symbol	Characteristic	-40°C			25°C			85°C			Unit
		Min	Typ	Max	Min	Typ	Max	Min	Typ	Max	
$f_{\text{maxPECL/HSTL}}$	Maximum Frequency (Figure 4)		3			3			3		GHz
t_{PLH} t_{PHL}	Propagation Delay (Differential Configuration)	325	400	475	350	430	500	440	510	590	ps
t_{skew}	Within-Device Skew (Note 15) Within-Device Skew @ 2.5 V (Note 15) Device-to-Device Skew (Note 16)		20 20 85	25 25 150		20 20 85	25 25 150		25 20 85	35 25 150	ps
t_{JITTER}	CLOCK Random Jitter (RMS) @ $\leq 0.5\text{ GHz}$ @ $\leq 1.0\text{ GHz}$ @ $\leq 1.5\text{ GHz}$ @ $\leq 2.0\text{ GHz}$ @ $\leq 2.5\text{ GHz}$ @ $\leq 3.0\text{ GHz}$		0.209 0.200 0.197 0.220 0.232 0.348	0.5 0.5 0.4 0.5 0.4 0.6		0.204 0.214 0.213 0.224 0.290 0.545	0.5 0.6 0.5 0.5 0.5 0.8		0.221 0.229 0.243 0.292 0.522 0.911	0.5 0.5 0.4 0.6 0.8 1.3	ps
V_{PP}	Input Swing (Differential Interconnect Configuration) Measured Single-Ended	150	800	1200	150	800	1200	150	800	1200	mV
$t_{\text{r}}/t_{\text{f}}$	Output Rise/Fall Time (20%–80%)	105	200	255	125	200	275	150	230	320	ps

NOTE: Device will meet the specifications after thermal equilibrium has been established when mounted in a test socket or printed circuit board with maintained transverse airflow greater than 500 lpm. Electrical parameters are guaranteed only over the declared operating temperature range. Functional operation of the device exceeding these conditions is not implied. Device specification limit values are applied individually under normal operating conditions and not valid simultaneously.

14. Measured with 750 mV source, 50% duty cycle clock source. All loading with $50\ \Omega$ to $V_{CC} - 2.0\text{ V}$.

15. Skew is measured between outputs under identical transitions and conditions on any one device.

16. Device-to-Device skew for identical transitions at identical V_{CC} levels.

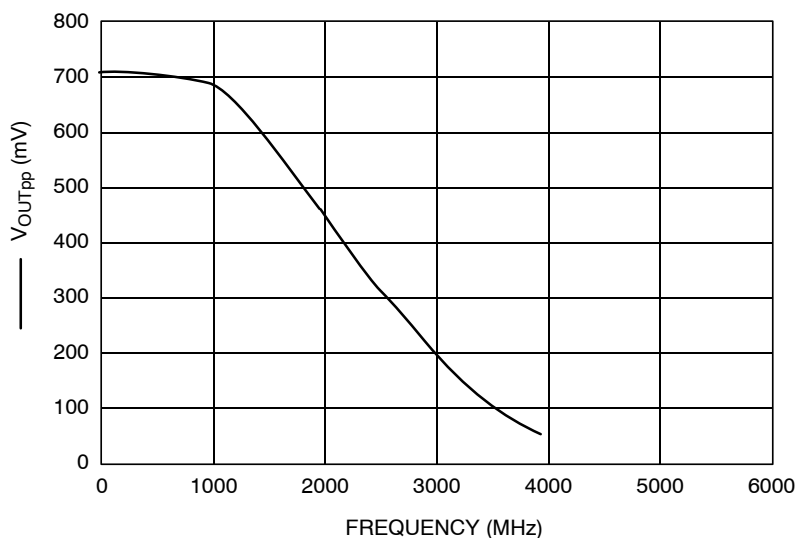

Figure 4. F_{max} Typical

MC100LVEP111

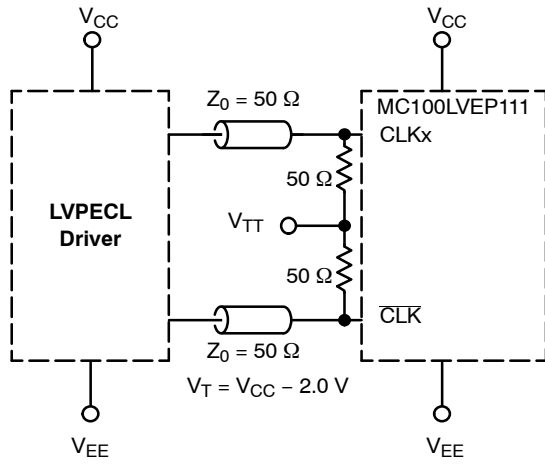

Figure 5. LVPECL in Interface

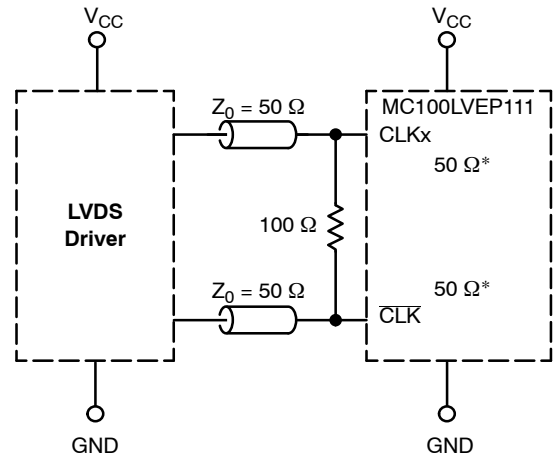

Figure 6. LVDS in Interface

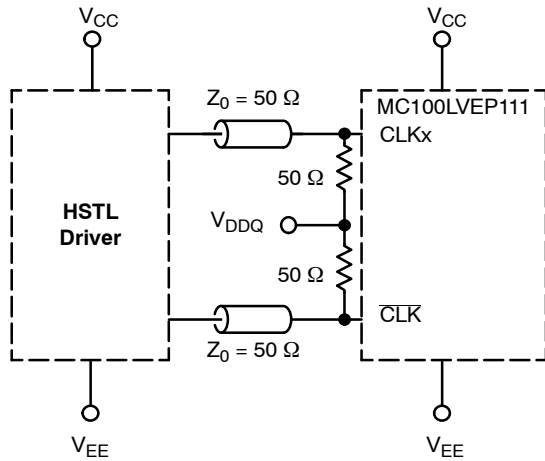

Figure 7. HSTL in Interface

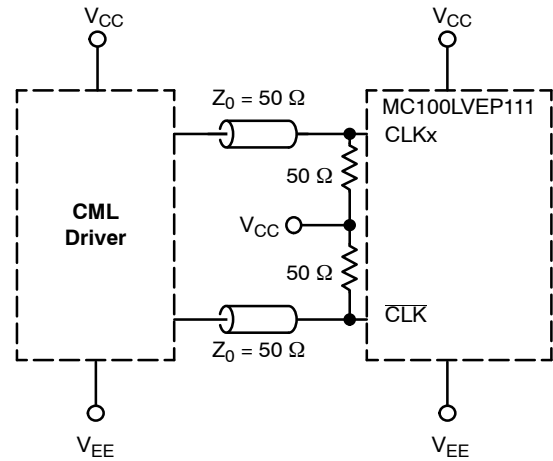

Figure 8. Standard 50 Ω Load CML in Interface

MC100LVEP111

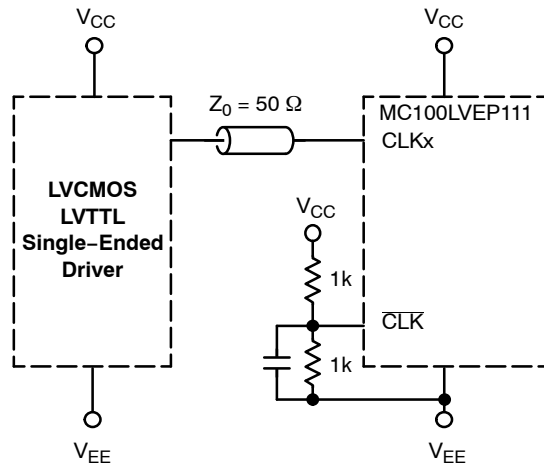

Figure 9. Single-Ended Interface LVC MOS/LVTTL in Interface Using an External Voltage Reference

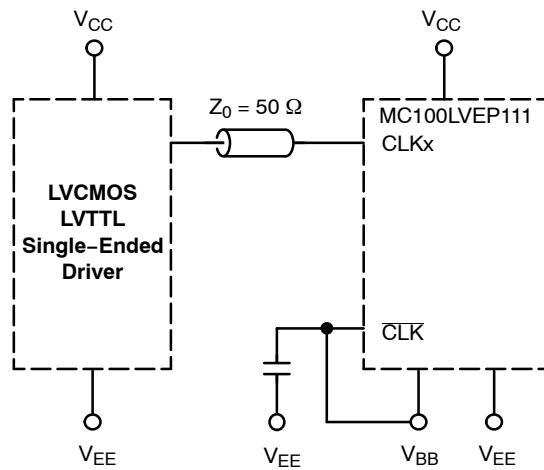

Figure 10. Single-Ended Interface LVC MOS/LVTTL in Interface Using V_{BB}

MC100LVEP111

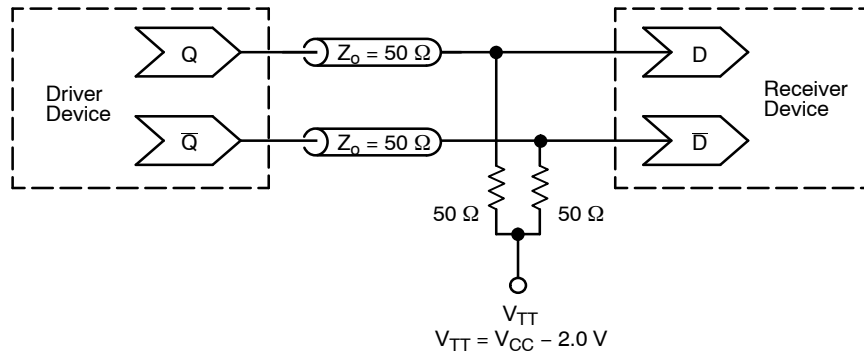

Figure 11. Typical Termination for Output Driver and Device Evaluation
(See Application Note AND8020/D – Termination of ECL Logic Devices.)

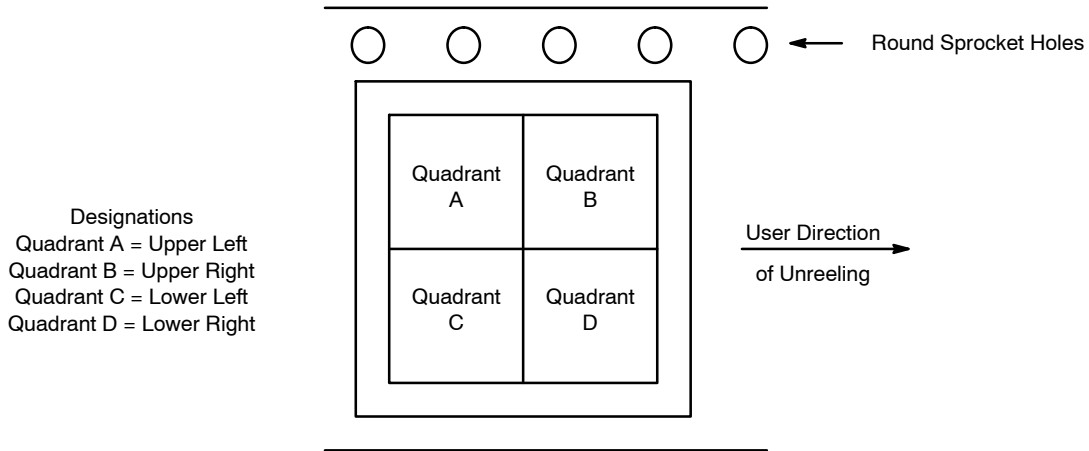

Figure 12. Tape and Reel Pin 1 Quadrant Orientation

ORDERING INFORMATION

Device	Package	Shipping†
MC100LVEP111FA	LQFP-32	250 Units / Tray
MC100LVEP111FAG	LQFP-32 (Pb-Free)	250 Units / Tray
MC100LVEP111FAR2	LQFP-32	2000 / Tape & Reel (Pin 1 Orientation in Quadrant B, Figure 12)
MC100LVEP111FARG	LQFP-32 (Pb-Free)	2000 / Tape & Reel (Pin 1 Orientation in Quadrant B, Figure 12)
M100LVEP111FATW	LQFP-32	2000 / Tape & Reel (Pin 1 Orientation in Quadrant A, Figure 12)
M100LVEP111FATWG	LQFP-32 (Pb-Free)	2000 / Tape & Reel (Pin 1 Orientation in Quadrant A, Figure 12)
MC100LVEP111MNG	QFN-32 (Pb-Free)	74 Units / Rail
MC100LVEP111MNRG	QFN-32 (Pb-Free)	1000 / Tape & Reel

†For information on tape and reel specifications, including part orientation and tape sizes, please refer to our Tape and Reel Packaging Specifications Brochure, BRD8011/D.

MC100LVEP111

Resource Reference of Application Notes

- AN1405/D** – ECL Clock Distribution Techniques
- AN1406/D** – Designing with PECL (ECL at +5.0 V)
- AN1503/D** – ECLinPS™ I/O SPiCE Modeling Kit
- AN1504/D** – Metastability and the ECLinPS Family
- AN1568/D** – Interfacing Between LVDS and ECL
- AN1672/D** – The ECL Translator Guide
- AND8001/D** – Odd Number Counters Design
- AND8002/D** – Marking and Date Codes
- AND8020/D** – Termination of ECL Logic Devices
- AND8066/D** – Interfacing with ECLinPS
- AND8090/D** – AC Characteristics of ECL Devices

MC100LVEP111

PACKAGE DIMENSIONS

32 LEAD LQFP
CASE 873A-02
ISSUE C

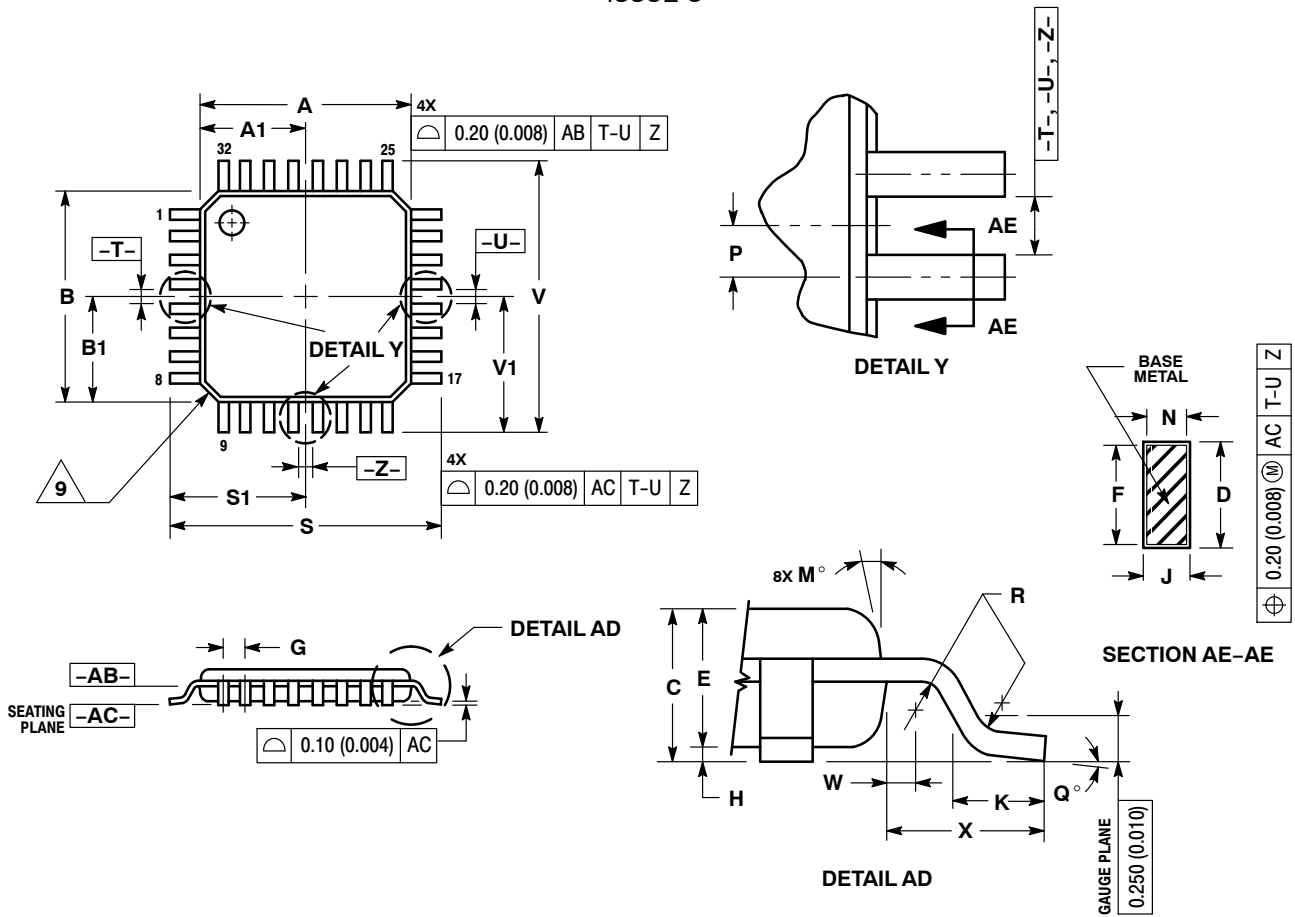

NOTES:

1. DIMENSIONING AND TOLERANCING PER ANSI Y14.5M, 1982.
2. CONTROLLING DIMENSION: MILLIMETER.
3. DATUM PLANE -AB- IS LOCATED AT BOTTOM OF LEAD AND IS COINCIDENT WITH THE LEAD WHERE THE LEAD EXITS THE PLASTIC BODY AT THE BOTTOM OF THE PARTING LINE.
4. DATUMS -T-, -U-, AND -Z- TO BE DETERMINED AT DATUM PLANE -AB-.
5. DIMENSIONS S AND V TO BE DETERMINED AT SEATING PLANE -AC-.
6. DIMENSIONS A AND B DO NOT INCLUDE MOLD PROTRUSION. ALLOWABLE PROTRUSION IS 0.250 (0.010) PER SIDE. DIMENSIONS A AND B DO INCLUDE MOLD MISMATCH AND ARE DETERMINED AT DATUM PLANE -AB-.
7. DIMENSION D DOES NOT INCLUDE DAMBAR PROTRUSION. DAMBAR PROTRUSION SHALL NOT CAUSE THE D DIMENSION TO EXCEED 0.520 (0.020).
8. MINIMUM SOLDER PLATE THICKNESS SHALL BE 0.0076 (0.0003).
9. EXACT SHAPE OF EACH CORNER MAY VARY FROM DEPICTION.

DIM	MILLIMETERS		INCHES	
	MIN	MAX	MIN	MAX
A	7.000 BSC		0.276 BSC	
A1	3.500 BSC		0.138 BSC	
B	7.000 BSC		0.276 BSC	
B1	3.500 BSC		0.138 BSC	
C	1.400	1.600	0.055	0.063
D	0.300	0.450	0.012	0.018
E	1.350	1.450	0.053	0.057
F	0.300	0.400	0.012	0.016
G	0.800 BSC		0.031 BSC	
H	0.050	0.150	0.002	0.006
J	0.090	0.200	0.004	0.008
K	0.450	0.750	0.018	0.030
M	12° REF		12° REF	
N	0.090	0.160	0.004	0.006
P	0.400 BSC		0.016 BSC	
Q	1°	5°	1°	5°
R	0.150	0.250	0.006	0.010
S	9.000 BSC		0.354 BSC	
S1	4.500 BSC		0.177 BSC	
V	9.000 BSC		0.354 BSC	
V1	4.500 BSC		0.177 BSC	
W	0.200 REF		0.008 REF	
X	1.000 REF		0.039 REF	

MC100LVEP111

PACKAGE DIMENSIONS

QFN32 5*5*1 0.5 P
CASE 488AM-01
ISSUE 0

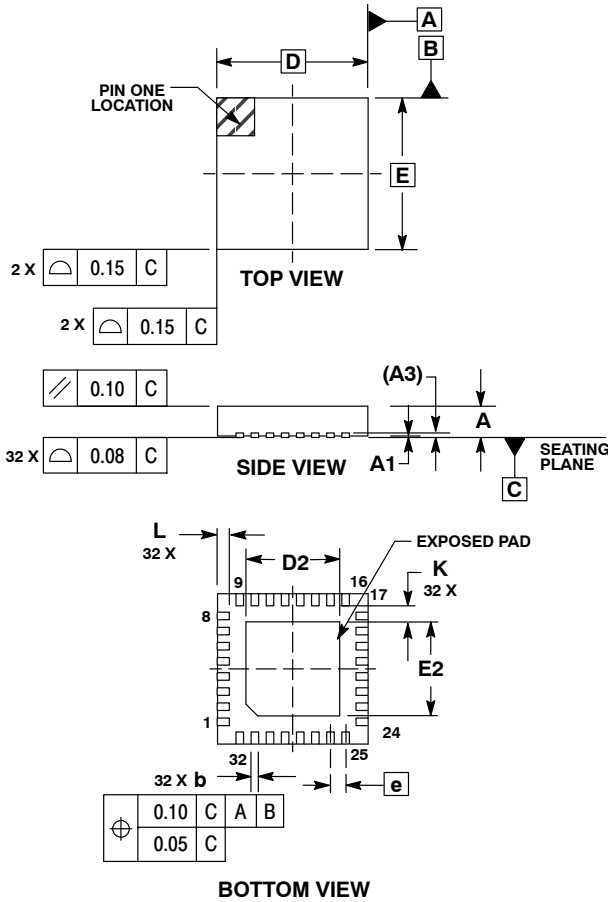

NOTES:

1. DIMENSIONS AND TOLERANCING PER ASME Y14.5M, 1994.
2. CONTROLLING DIMENSION: MILLIMETERS.
3. DIMENSION b APPLIES TO PLATED TERMINAL AND IS MEASURED BETWEEN 0.25 AND 0.30 MM TERMINAL.
4. COPLANARITY APPLIES TO THE EXPOSED PAD AS WELL AS THE TERMINALS.

MILLIMETERS			
DIM	MIN	NOM	MAX
A	0.800	0.900	1.000
A1	0.000	0.025	0.050
A3	0.200 REF		
b	0.180	0.250	0.300
D	5.00 BSC		
D2	2.950	3.100	3.250
E	5.00 BSC		
E2	2.950	3.100	3.250
e	0.500 BSC		
K	0.200	---	---
L	0.300	0.400	0.500

SOLDERING FOOTPRINT*

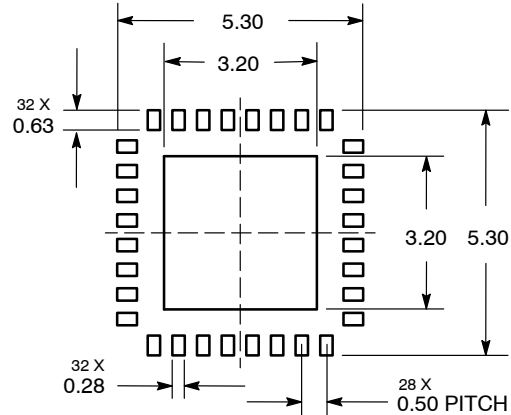

DIMENSIONS: MILLIMETERS

*For additional information on our Pb-Free strategy and soldering details, please download the ON Semiconductor Soldering and Mounting Techniques Reference Manual, SOLDERRM/D.

ECLinPS is a trademark of Semiconductor Components Industries, LLC (SCILLC).

ON Semiconductor and are registered trademarks of Semiconductor Components Industries, LLC (SCILLC). SCILLC reserves the right to make changes without further notice to any products herein. SCILLC makes no warranty, representation or guarantee regarding the suitability of its products for any particular purpose, nor does SCILLC assume any liability arising out of the application or use of any product or circuit, and specifically disclaims any and all liability, including without limitation special, consequential or incidental damages. "Typical" parameters which may be provided in SCILLC data sheets and/or specifications can and do vary in different applications and actual performance may vary over time. All operating parameters, including "Typicals" must be validated for each customer application by customer's technical experts. SCILLC does not convey any license under its patent rights nor the rights of others. SCILLC products are not designed, intended, or authorized for use as components in systems intended for surgical implant into the body, or other applications intended to support or sustain life, or for any other application in which the failure of the SCILLC product could create a situation where personal injury or death may occur. Should Buyer purchase or use SCILLC products for any such unintended or unauthorized application, Buyer shall indemnify and hold SCILLC and its officers, employees, subsidiaries, affiliates, and distributors harmless against all claims, costs, damages, and expenses, and reasonable attorney fees arising out of, directly or indirectly, any claim of personal injury or death associated with such unintended or unauthorized use, even if such claim alleges that SCILLC was negligent regarding the design or manufacture of the part. SCILLC is an Equal Opportunity/Affirmative Action Employer. This literature is subject to all applicable copyright laws and is not for resale in any manner.

PUBLICATION ORDERING INFORMATION

LITERATURE FULFILLMENT:
Literature Distribution Center for ON Semiconductor
P.O. Box 5163, Denver, Colorado 80217 USA
Phone: 303-675-2175 or 800-344-3860 Toll Free USA/Canada
Fax: 303-675-2176 or 800-344-3867 Toll Free USA/Canada
Email: orderlit@onsemi.com

N. American Technical Support: 800-282-9855 Toll Free
USA/Canada

Japan: ON Semiconductor, Japan Customer Focus Center
2-9-1 Kamimeguro, Meguro-ku, Tokyo, Japan 153-0051
Phone: 81-3-5773-3850

ON Semiconductor Website: <http://onsemi.com>

Order Literature: <http://www.onsemi.com/litorder>

For additional information, please contact your local Sales Representative.